

# lande

#1.3E

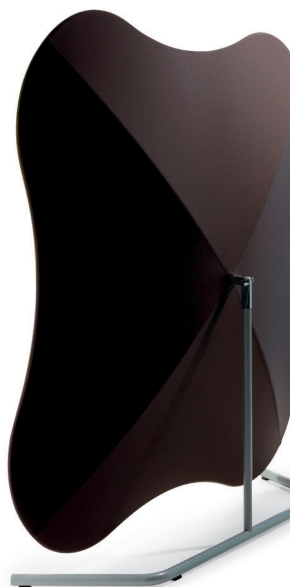

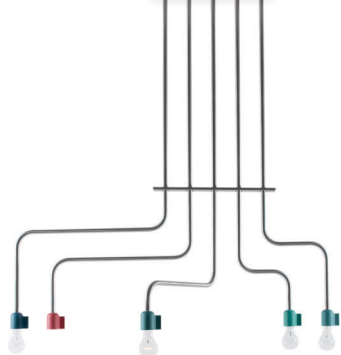

There is an increasing demand for a different way of working and living. It means abandoning work as a status symbol and embracing work as an enrichment of your life. A major role in this is played by meetings, sharing knowledge, freedom to create, co-creation and developing talent. Or, in other words, living, working, discovering and enjoying.

For this, Lande creates Meeting Places and Working Environments.

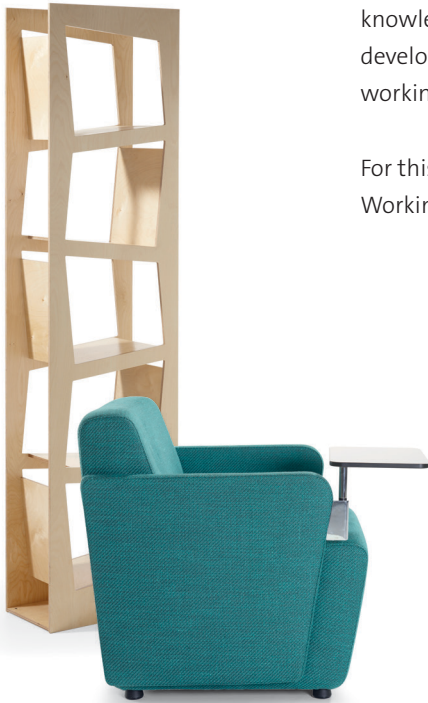

## Benches and arm chairs



2 Buggy Back Seat



4 Buggy Outdoor



6 Dots



10 Dots Up



12 MC Sofa System



14 Olli

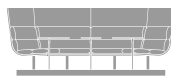

16 Turning Talks

## Concentration units



18 1st Class

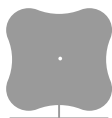

20 Dive

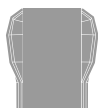

22 Dug out



24 Rondo



28 The Shadows

## Conference chairs



30 Flow



32 Ray



34 Runner



36 X-Ray

## Chairs



38 Cole



40 Cube



42 Hopper



44 Icon



46 Jami



48 Mila



50 Spirit



52 Toro



54 Tree Trunk



56 X-Ray Spin

## Tables



58 Aluxx



60 Buggy



62 Casus



64 Cheek



66 Club



68 Leaf



70 Level



72 Ping



74 Slick



76 T-pad



78 Teska



80 Trigon



82 Hot Desk

## Illumination



84 Illuminate

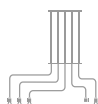

86 Refinery



88 Tangible Light

## Cabinets



90 Cabinet 45



92 6 Degrees

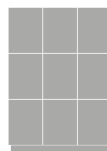

94 System

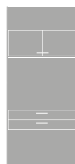

96 Wiet

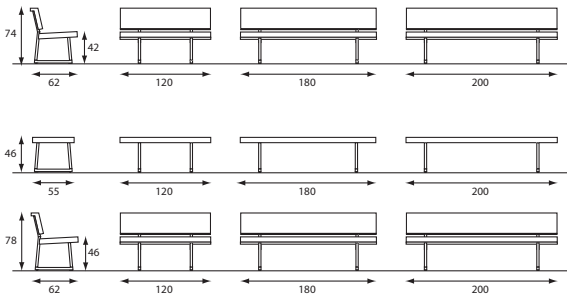

## Just take a seat.

Beautifully simple, the Buggy Back Seat is slim and sturdy at the same time. With its stylish steel frame and cast aluminium bracket base, this sofa provides firm, comfortable seating. Available with or without backrest. The upholstery softens the otherwise strong appearance. Beautiful in every style and colour, the Buggy Back Seat is both striking and a perfect match for its surroundings.

Whether you want to eat, talk, learn or laugh, just take a seat. And not just on your own because there are various lengths, so that everyone has enough space.

The Buggy Back Seat is part of the Buggy Collection. The tables also feature the characteristic tapering base, which gives this collection its specific slim, sturdy elegance.

Buggy Back Seat. Always a perfect match.



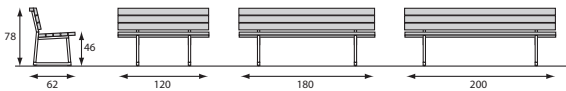
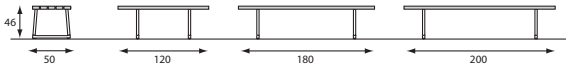
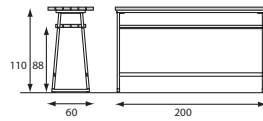
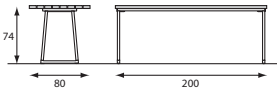

## Outdoor life.

An outdoor feel, even indoors. Pure and straight-forward. A great place to sit.

Together with the table and standing table, the buggy Outdoor creates an inviting environment. Enjoy the freedom and space. This is a place where you want to be. Its natural, robust appearance - both indoors and out - comes through its shape and its durable materials: Garapa wood and steel.

The sofas are available in two lengths, with or without backrests. Strong, open, pure and straight-forward, the Buggy Outdoor is perfect for public areas, schools and canteens. The Buggy Outdoor also features the characteristic tapering base, which gives the Buggy Collection its typically slim and sturdy elegance.





Photography Valerie Clarysse

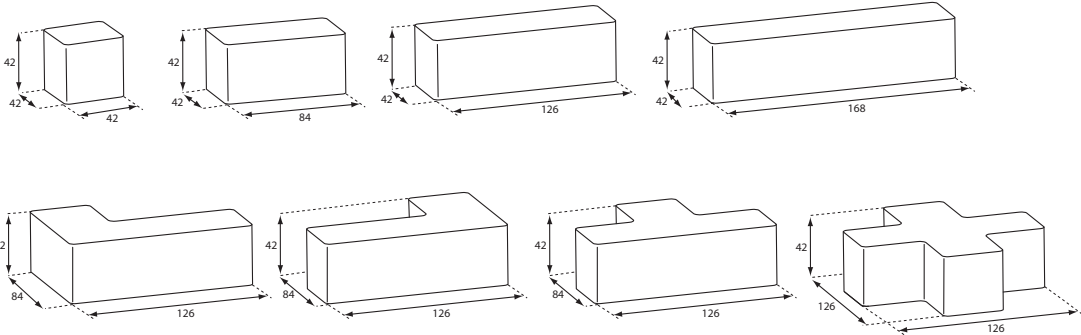



## Play and combine.

Fancy something different? No day is the same with Dots. Just change them around, put them together and combine. Exactly the way you want, and the way you like.

The shape ensures sitting comfort. From stools to letters and from donuts to curves – just play with the elements and enjoy the results. Create group encounters or places to be alone together. Move together and create energy. Everyone feels welcome.

Work, play, eat and watch. Dots' smooth upholstery and rounded corners simply invites you to sit down. Wherever you are and whatever you're doing. Just try it out – sitting, lounging, lying down. With Dots, everything is possible.





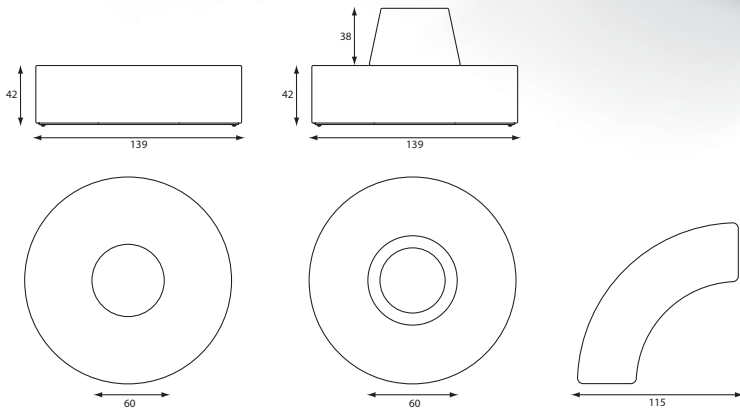



## A special effect from wherever you look.

Everything is possible with these different wall combinations. Let your imagination go and create great-looking corners. A new setting for every moment and event. In colour or black & white: a special effect from wherever you look.

Dots Up is a statement, but it's cuddly. Its upholstery makes in pleasantly sturdy and it even absorbs noise. Which makes Dots Up effective in large or small rooms if you want to meet or wait while relaxing.

Dots Up's different heights make it even more versatile. You can opt for the overview, or more privacy, or both. All of the wall elements are 21 cm wide and complement each other perfectly. Also available with the regular Dots seating elements.

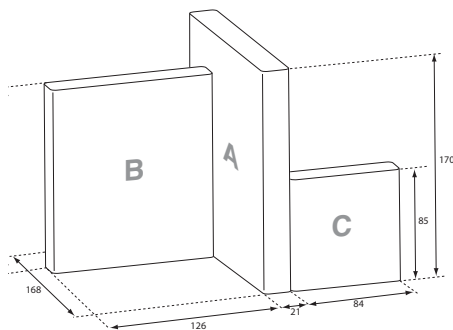
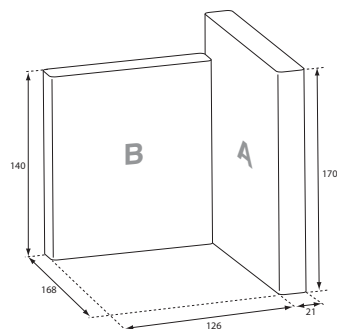
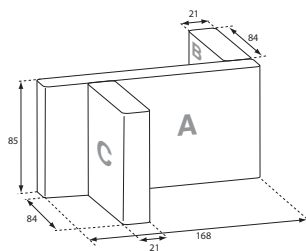



Photography Valerie Clarysse

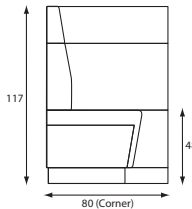
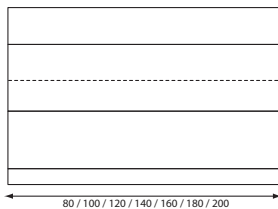
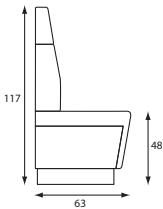
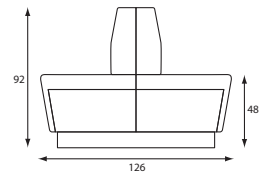
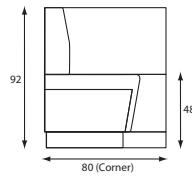
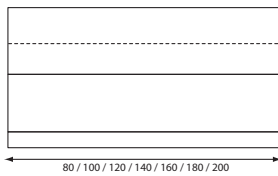
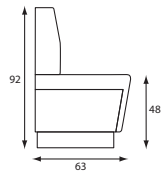

## Your personal bench-seat.

Sit down to a meeting, get your breath back, enjoy a meal, lounge on the sofa together or brainstorm. This is a sofa that brings people together and gets them talking. A sofa that invites you to take part, in an open workplace where everyone feels at home.

Visually imposing, beautiful against a wall or standing alone. The high backrest provides comfort and better protection from noise. Combined with a low back, you can create an open, light-hearted effect, which you can emphasise with the upholstery and various finishes. As a work and dining table, the Club table matches the style of the sofa well – as if they were made for each other.

And if you have specific wishes, the MC Sofa can be made to measure exactly.



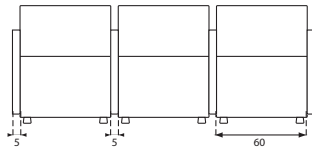
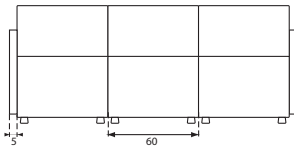
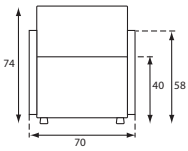
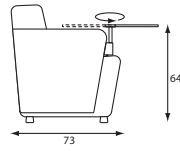
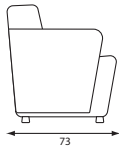
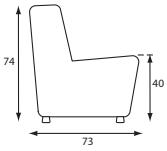



## **A luxury fauteuil. Compact and flexible.**

Olli gives every room extra élan. This luxury fauteuil is amazingly comfortable and its thick sprung seat will ensure years of pleasure. What's more, you can link Olli to make a snug two-seater or a long, continuous sofa for ten, twenty or many more people. By playing with colour and elements, you can constantly change the setting and atmosphere.

However it's combined and arranged, Olli is always compact, flexible and inviting. Every element is based on simplicity. Pure and solid, trusted and snug. The armrests lend Olli the appearance of a luxury fauteuil. And with arm fittings, Olli combines luxury with a business-like flair.

Olli is comfortable everywhere – at home, at work and meeting places, and in an entrance or foyer.



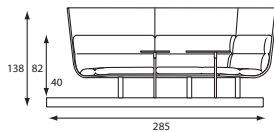
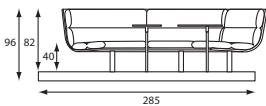
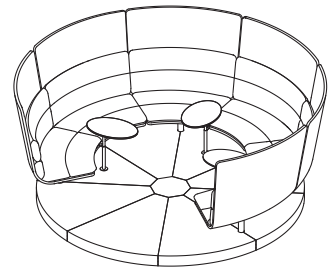
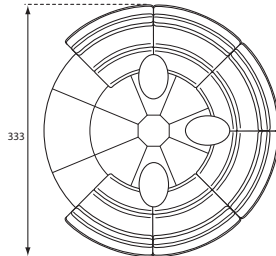
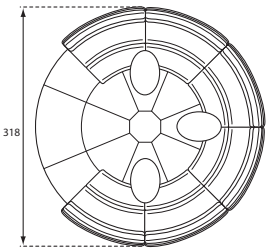



## Discover new creativity.

A place to meet and talk, a working environment, a combination of ideas and creative solutions – that's Turning Talks. This brainstorming spot gets enthusiastic reactions wherever it is, inviting you to explore new angles. This is an exceptional design in which the new way of working blends seamlessly into the new way of living – developing talent through connection, experience, meeting, enjoyment and flexibility.

Turning Talks can be used as a more closed unit, or very open. The choice is yours. Turning Talks features three swivelling tables. It also comes with low and high walls – or a combination – so that you can always choose between focus and open space. If you want extra inspiration, then just turn Talking Talks towards the view you want. And thanks to the platform, that's very easy.

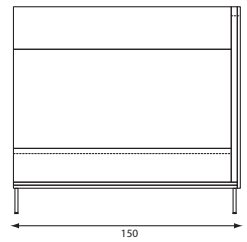
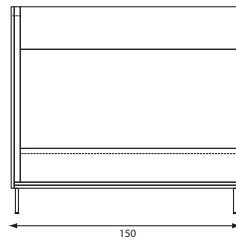
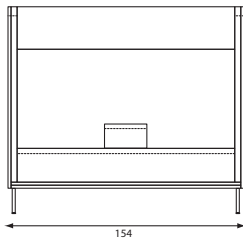
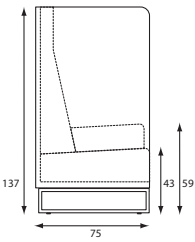

## Luxuriously comfortable. Surprisingly practical.

On the way to your objective, you should enjoy the journey. Who and what do you meet with? What do you want to achieve? Where do you feel comfortable? Many answers concern your surroundings – where you are, what your intentions are, how you can work.

1st Class enables you to create your own environment. As a place to lounge, a divider, an individual waiting sofa or linked in a row. Open or focused on the surroundings. If you want to discuss, or simply to chat, you can quickly create your own room by simply placing two elements opposite each other. The matching ceiling with lighting accentuates the space and improves the acoustics.

Thanks to its slim frame and taut upholstery, the 1st Class remains elegant and airy. This luxurious divider-lounge sofa is extremely comfortable, has padded walls and is available in various colours and combinations.

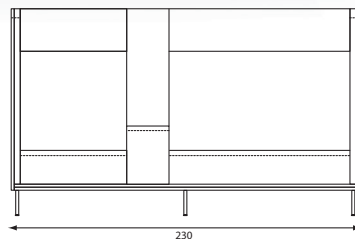
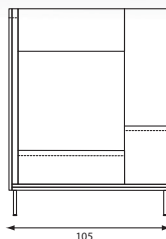
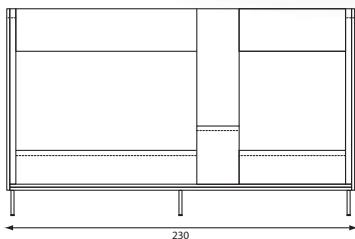

## Flower Divider.

Pop over to the other side to work in peace and concentrate. Divide the room and still remain in touch. Dive is a felt screen in the shape of a flower that's light and striking thanks to its organic shape and felt finish. Beautiful in every colour – and extra special in two-tone.

Dive can also be attached to the ceiling as a striking accent or as a special element to lower the ceiling. Thanks to its light construction, you can easily (re-)locate it to create an intimate area. And one more plus point: the felt improves the acoustics.

Dive. Shapes space, noise-friendly, flexible to position, stylishly effective.



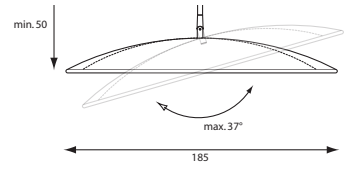
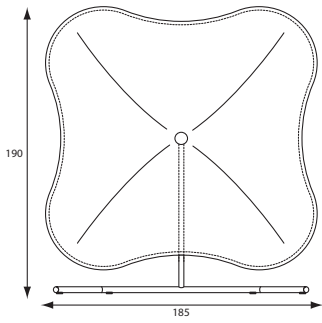

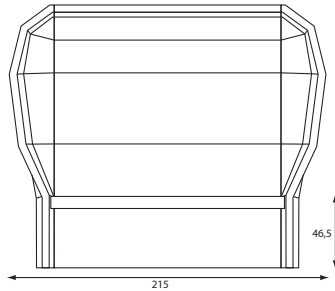
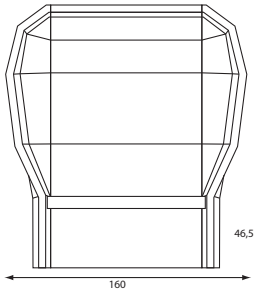
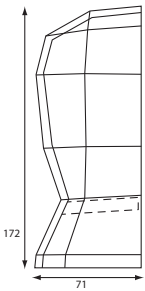



## A sculpture, a workplace, or somewhere to hang out.

This is one Dug-Out that you'll love to sit in. For concentration, new insights, ideas and solutions. Or for quiet discussions in hectic, busy surroundings. Or just for a chat – snug and informal.

Dug-Out is built from sections. You can choose from various colours and fabrics. A real eye-catcher, without unnecessary frills.

Dug-Out provides peace and quiet – a place to concentrate. Put a few Dug-Outs together and you can go in two directions: either a defined area for concentration and discussion, or a place to relax together, share ideas and celebrate successes.







## All Round.

Change the dynamics of the working environment in a single step. From hectic to peaceful, from broadly focused to relaxed. In the new way of working, people look for places where they can reflect uninterrupted or where a quiet discussion is possible.

Thanks to its various shapes and possibilities, Rondo can create these individual workplaces, meeting corners and free-and-easy presentation areas. Allowing you to lay out an open office or room entirely to your wishes. Without sacrificing openness.

From single workplace to a brainstorming area with screen and speakers. And from a two-seater to a telephone booth. All the elements have friendly rounded lines. Combined with its cheerful colours, Rondo stimulates creativeness. This is a place where you want to work.



Quattro Cinema has a 40" LED screen built into its 8 cm-thick wall. And it's hidden behind a smoked-glass panel, so it's almost invisible when off. Sharing information during a meeting can be done wirelessly via iPhone, iPad or notebook or wired via the HDMI input.

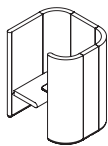

Rondo Solo

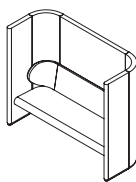

Rondo Duo

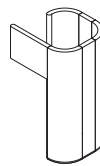

Rondo Longo

Total width	1155	1950	930
Total depth	930	775	930
Total height	1427	1627	1877
Seat height	434	434	nvt
Seat width	780	1800	nvt
Seat depth	460	460	nvt

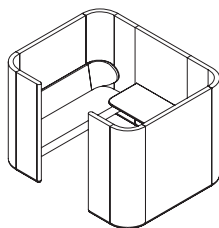

Rondo Quatro

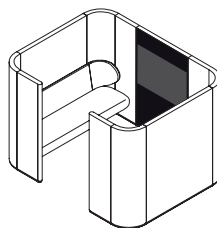

Rondo Quatro Cinema

Total width	2480	2480
Total depth	1950	1950
Total height	1627	1627
Seat height	434	434
Seat width	1800	1800
Seat depth	460	460
Table 400mm	standard	optional
Table 1400mm	optional	optional

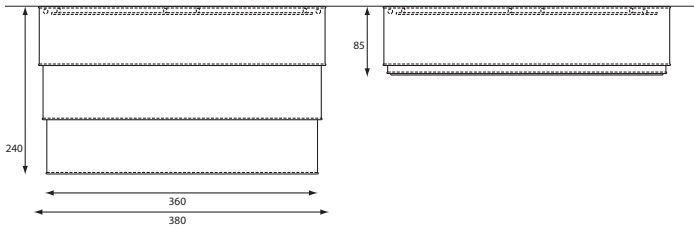

## Now you see me.

Open and hanging from the ceiling, it creates the illusion of a large, floating lampshade. The light, slightly transparent material makes it an elegant object that draws attention. This is where it happens. This is the place and time for reflection and innovation. For inspiration, plans and action.

### **Space for your own place**

For more focus, just lower the rings and you can easily make a special place for yourself with its own atmosphere. A stand-alone workplace in which you can work and brainstorm in seclusion, like a sort of cocoon. Sounds and shadows keep you in touch with your surroundings, while temporary visual screening strengthens interconnection.

Use the dimmable lighting to create the atmosphere you want: action, inspiration, sociability, openness, focus. The Shadows has optional built-in speakers and can be printed according to your wishes.



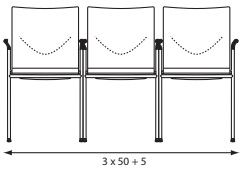
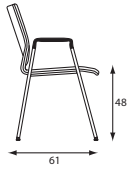
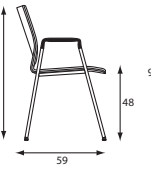
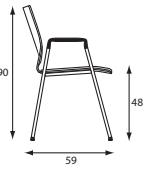
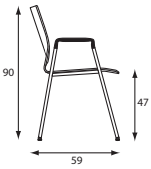
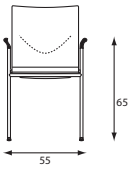



## Quick to link.

Business-like, sober, with a wide seat. A conference chair with one objective: comfort. Very quick to link and compact to stack. For flexible and multifunctional rooms. From auditorium to canteen and event to meeting.

Flow combines all the benefits of well thought-out design with practicality. It stands firmly on tubular legs, provides support on both sides and space where it's needed. Available in various colour combinations. Business-like with a twist.

Can be used separately or linked together for conferences. That's where the special linkage comes in: the arms have been designed to enable very compact linking.

Join the Flow and see it work.

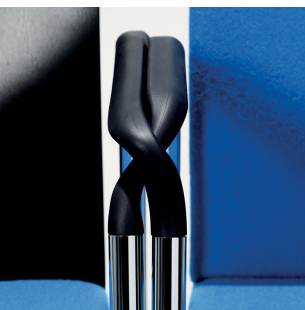

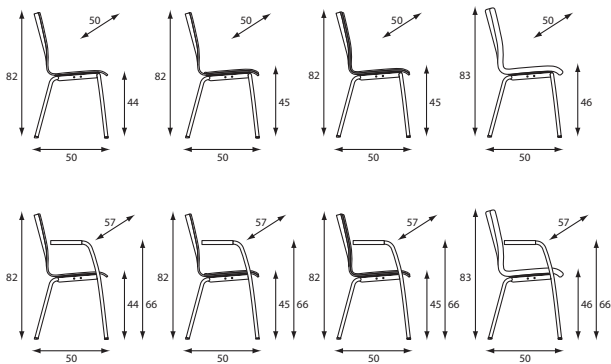

## More than just a chair.

Wherever you want to sit, Ray is perfect. This is more than just a chair: it's no-nonsense, attractive, solid and multi-functional. A detail worth mentioning is that the curved armrests are separated from the backrest and run through the frame. This gives the chair a tough look, both in the sled base and four-leg versions. Without the arms, the four-leg Ray has a different look – somewhat subtler and slightly cheeky.

In fresh powder-coat colours, with or without upholstery and writing tablet. Choose from various models, materials and colours. Ray satisfies all expectations, which means that it's also stackable and linkable with row and chair numbering.

Ray: the conference chair with more comfort and possibilities.



## A cheerful chair with serious quality.

Sustainable to Dutch government criteria and fully recyclable. And it's also beautiful, comfortable, practical and available in all sorts of versions.

By combining colours and upholstery, every model acquires something unique. From soft pastels and fresh, lively colours to elegant ton-sur-ton. In your house style or perfectly matched to the dynamics of the room.

Whether you're listening actively for half an hour, taking a relaxed hour for lunch or taking part in a marathon meeting, it's always important to sit comfortably. Runner is designed for comfort. Its armrests provide extra support and the upholstery in horizontal strips lends it a stylish accent.



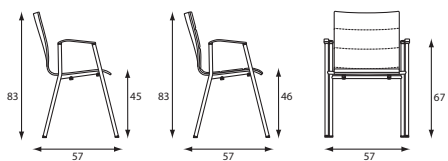

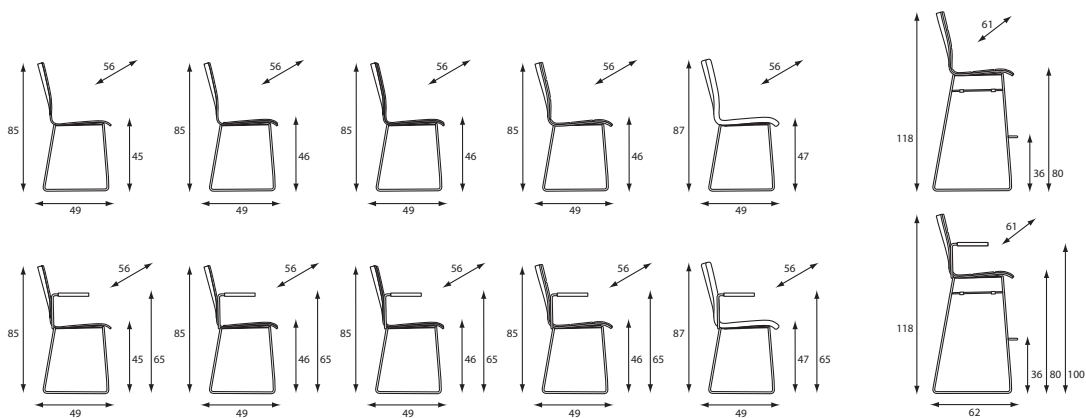

## Typical X-Ray

Light, air and space. Carefully considered design. Durable. Flexible. Inviting. 'Come and sit next to me and let's swap a few ideas.' Choose your shape, height and comfort and feel at home no matter where you are. Its wire frame makes the X-Ray open and light. And if you want more space, the X-Ray also looks great when stacked.

### With the X-Ray you're sitting pretty.

Always comfortable with or without upholstery. Prefer an upholstery inlay in the shell or seat? No problem. Neither are leg caps for silent movement and plastic armrests that can also be hooked onto the table if the floor has to be free. Set the X-Ray out in a row and the effect is seamless. Perfect for active listening, or simply enjoying.

And if you want even more individuality, the X-Ray's minimalism makes it really stand out as a bar stool.

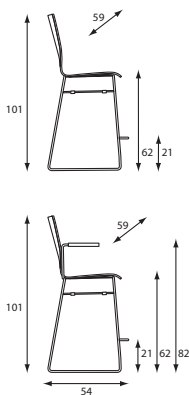

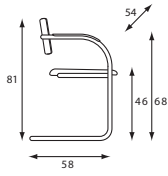
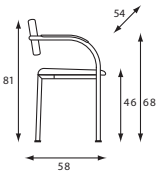



## Old school. New classic.

The name says it all. Cole Classic is... a classic. You can find it in the most unexpected places. On its own or in greater numbers. Clear and distinctive, elegantly comfortable and practically stackable.

Cole Classic moves with the times, without forgetting its roots. There are new colours and combinations. But the arms remain, because they're simply part of the chair. Choose your colour and go for a retro-look, an office icon, old-school or the timeless basic version.

A timeless classic for everyone.



lande

Cube

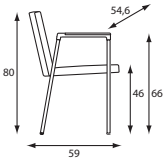

## Angular, with a soft heart.

Straight up and square. You can see it in the backrest, the cushion and even in the tube that runs straight down from the armrest into the legs. And the armrests are beautiful, with solid wood inlays. The foam shell is great to sit in, even after heavy use. The flat bottom means that there are no imprints in the upholstery after compact stacking. And you can still feel the softness. Quality that you can see – and experience - clearly.

Cube. Extra special in striking colours. Sturdy and elegant with black upholstery. Matches many types of meeting tables and is a welcome guest at the team table.



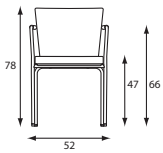

Hopper ST

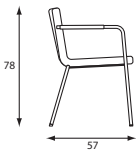

Hopper RO

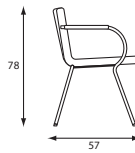

Hopper CE

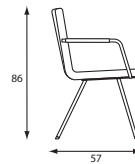
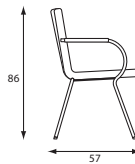
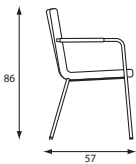
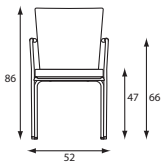
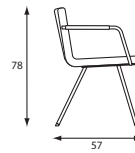

## One chair that hits three targets. Rounded. Graceful. Straightforward.

Would you opt for beautifully rounded, cheekily oblique or straightforward? All three are different but thanks to their graceful lines they are clearly members of the same family.

With a high or low back, with or without armrests, stackable, sloping legs, fabric or leather. Every chair has the same high quality, comfort and durability.

Create a restful effect by repeating the colour and model. If you prefer something different and playful, mix all the shapes and colours together. A chair that fits in just as well around the dining room at home as at a flexi-workplace or head office.



## Icon

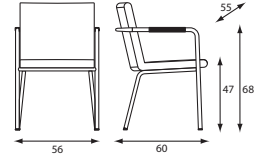
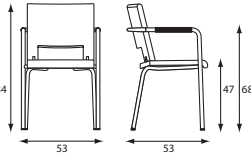
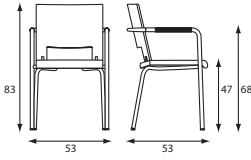

## Icon Plus

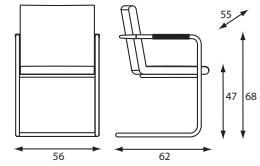
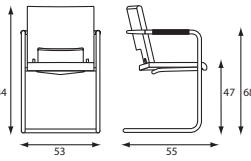
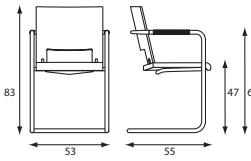

## The chair as icon. Sublimely comfortable.

From wherever you view it, this is a beautiful design. Solid with soft lines. Comfort and space. Design that supports you. The chair as icon. And sublimely comfortable. For ten minutes or a whole day. In big rooms or small, at conferences or meetings, the Icon brings elegance and style wherever it is.

### **Icon**

Both the four-leg and sled-base versions are also available in stackable models. The chair gets its airy appearance from the backrest with its rectangular opening. Beautiful in beech, fabric or veneer. The seat is upholstered as standard.

### **Icon Plus**

This chair raises the bar for comfort. The back and seat cushions are generously upholstered. With various options such as saddle-leather sleeves for the armrests and coloured stitching for an extra accent.



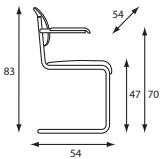
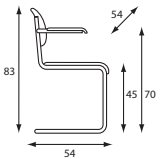
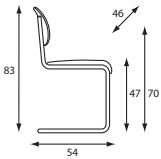
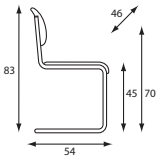



## A design classic in corduroy and Bakelite.

Wood, corduroy, Bakelite and chrome. You could even recognise this chair with your eyes shut. You just have to think about the films of yesteryear, or the schoolroom before or after them, or the trendy family you used to know. And then think of all the possibilities and applications now.

Jami is a textbook example of a classic that continues to touch the right chord. Timeless. Comfortable. Sober and yet beautiful. Then, now and in the future



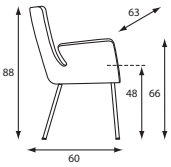

## Homely and comfortable.

Mila is a luxury chair with a friendly look and soft, rounded lines. This is a chair that you just love to sit on. And relax. Sit around the table for ages. Or maybe chair the meeting first, and get that job finished.

This chair is made to support people comfortably, so that they really relax. Thanks to its removable seat cushions, Mila is also very easy to clean. Available in leather and fabric.

Mila's slightly higher backrest makes it an ideal, stylish chair for the meeting table or team table. It's also a fine desk chair, dining-room chair or fauteuil. And Mila is a real asset in healthcare organisations.



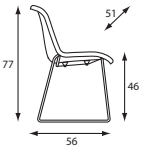

## The art of plastic.

Experience the Spirit of steel and plastic. Slim, elegant and beautifully shaped, with a natural curve. Which makes it great to relax in. Beautiful in its simplicity, both as a chair and an object. Stand-alone or next to each other in a row.

Looks striking at the dining-room table, in waiting areas and special locations. Spirit adds that touch of lightness, thanks to its wire frame with high-quality plastic shell. Stylish in black and white.





## Friendly beast

Hola! What's that? Toro is an all-in-one statement. It's ideal for ergonomic sitting, or just to lean on. With a handy writing table and coat-hanger, it's a workplace, a chair for conversations and a striking object in itself. A friendly beast of lacquered wood with close-fitting upholstery. And it's so inviting that you just can't help sitting on it.

Wherever you put it, Toro provokes reactions. Put two Toros next to each other and you have a creative corner.



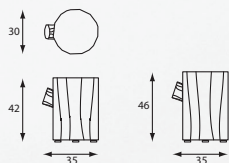



## A solitary stump.

Taste the air of freedom and just sit down. The Tree Trunk collection consists of small, metal works of art. Their curved lines come from ground sheets of metal. Once bent into the right shape, you have Tree Trunk. Beautiful as a side table, object and stool.

Place a couple of Tree Trunks next to each other and create variations in height and colour. Create a miniature landscape as a meeting place for persuasive arguments, smart solutions and innovative ideas. Or place a solitary stump as a decorative object and a handy side table.



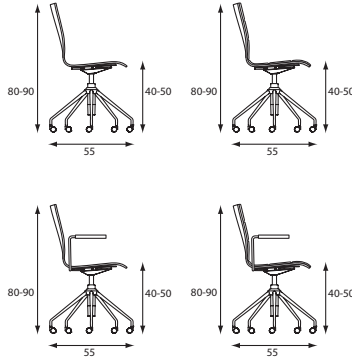

## A real desk chair. Only more creative.

With its light, creative appearance, this chair certainly appeals to the imagination. You can adjust X-Ray Spin to be high or low to get exactly the right degree of comfort. It offers complete freedom of movement, and a lot of possibilities. From a plain wooden shell to sumptuous upholstery in a beautiful panel design. This chair welcomes you with open arms. Or without arms, if you want.

Wonderfully comfortable, space-making and looks good at the meeting table. Elegant at your desk and attractive in flexible workplaces. With wheels for extra speed.

X-Ray Spin. A great balance between work and relaxation, that you can see and feel.



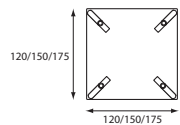
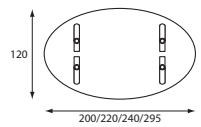
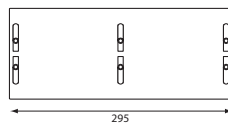
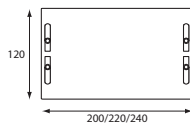
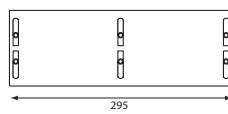
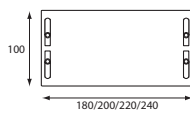
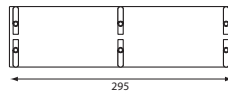
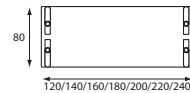
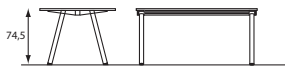

## Multifunctional with allure.

You only have to look at it. Aluxx is a table with allure that fits into every working environment – from modern to historic and from commercial to industrial. The slightly tilted legs lend the table its own style: architectonic and open. A table with a sturdy backbone. Durable, stable and ergonomic. You'll see it in boardrooms, open-plan offices and open areas. But also at home and in a flexible working environment.

The adjustable legs provide a good working height. Great as a stand-alone table or desk; ideal in large groupings, linked or not. Aluxx shapes space.

Combined with the right chair, this chair gets exactly the appearance you're looking for.

It also makes a beautiful standing table.

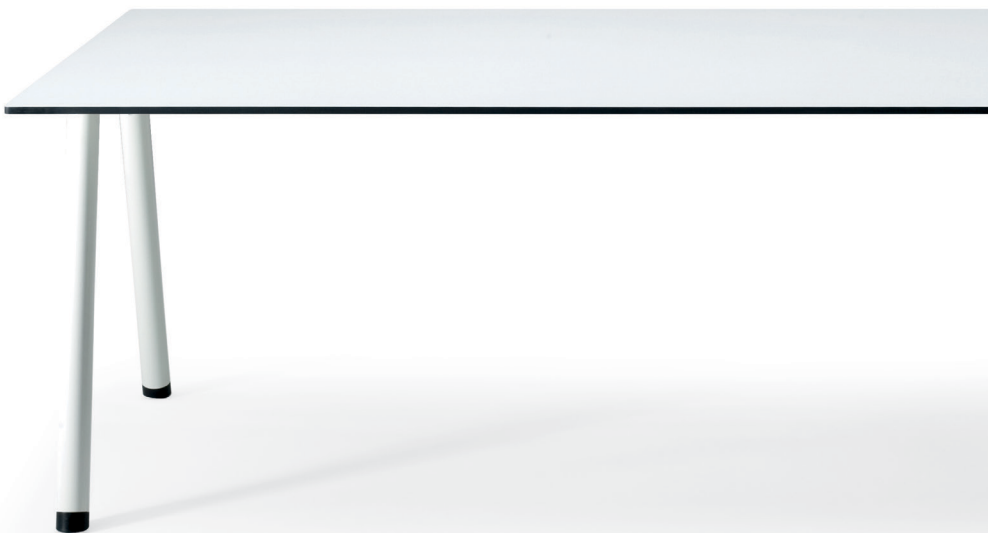

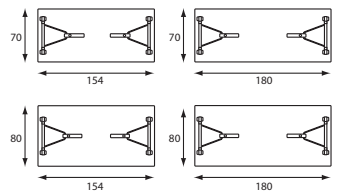
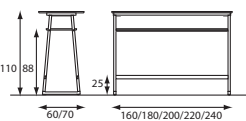
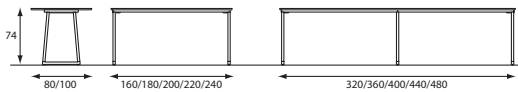
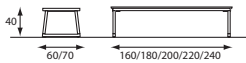

## Elegant with a playful accent.

As a stand-alone table, Buggy catches your eye straight away. Light and subtle with great attractiveness. And when it's linked, it's simply irresistible. In all its forms, Buggy just weaves its way through buildings left, right and centre. As a conference table, landing place or work-table. With Buggy you can do anything. In fact, this table affects the way you experience space.

Elegant and open, with the thin, white top and its typical brackets. Practical and beautiful with its matching knee walls and cable ducts. Strong and stable thanks to its striking legs. Also available as a folding table, standing table and coffee table.

Buggy. Always in great shape.



## Charming yet business-like.

Stylish, practical, with a charming, business-like appearance. A table for active, relaxed, energetic, decisive moments. Beautifully finished with an eye for detail. Available with different tops and legs. Can be used in any arrangement. Flexibility and practicality, elegance and openness all come together in the Casus.

Combined with a brightly coloured chair, the Casus acquires a rather cheeky character. It's a table for new ideas and spontaneous action. And if the room and the work call for a more restrained or clear-cut atmosphere, the right chair will provide the appearance you want.

With Casus, you can do anything. Always in style.





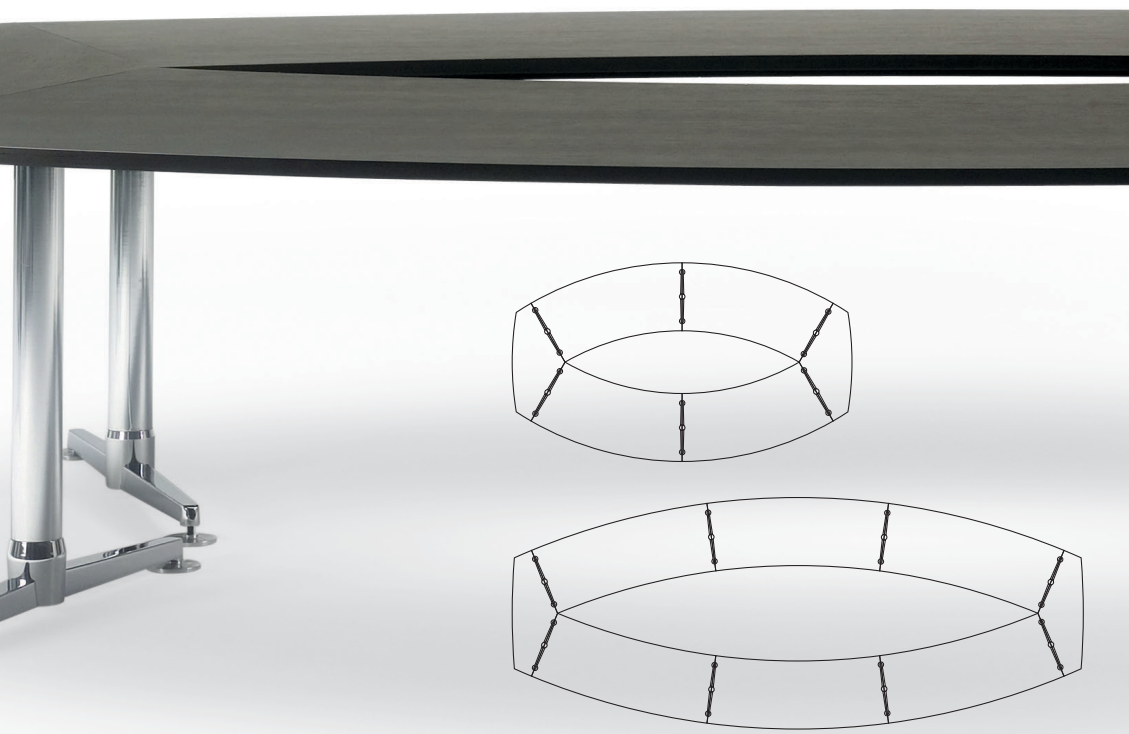
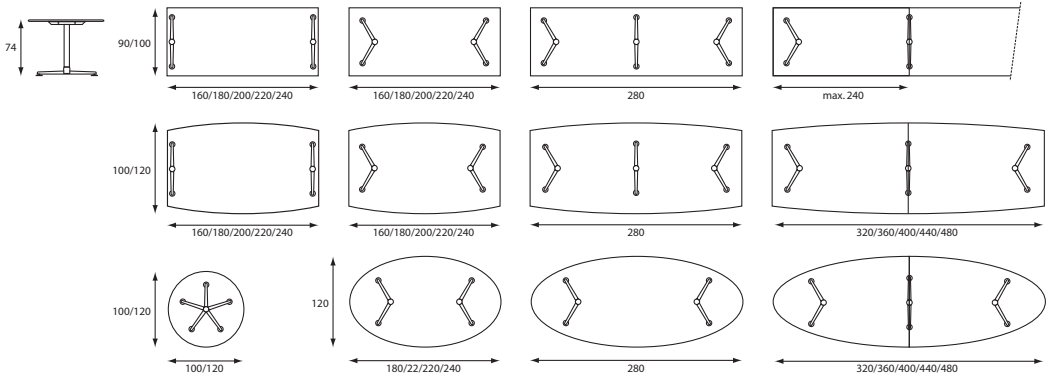



80 / 100

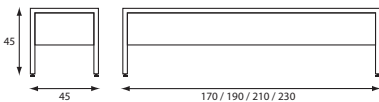
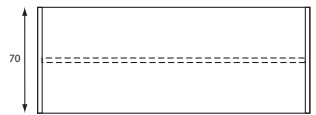
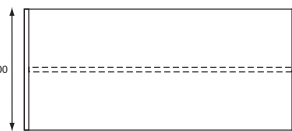

170 / 190 / 210 / 230

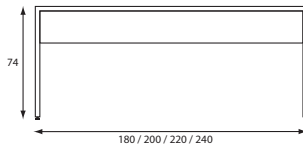

180 / 200 / 220 / 240

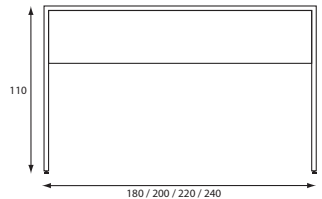

180 / 200 / 220 / 240

## Cheek to Cheek

Whether in an office, canteen, conservatory or waiting room, Cheek feels at home everywhere. A distinctive table where everyone feels at their best. Whether they're waiting, eating, reading or working. Need a long table? Then just link them cheek to cheek to easily get the right length. Cheek can be beautifully combined with sofas or separate stools for a playful effect. And as a high table, it's an asset for any space. Everything is exactly in the right proportions: from materials to finish and from design to practicality. It's beautifully simple. Sober and sturdy in laminate or veneer. With straight lines, mitred corners and closed ends for volume.

Cheek is available in various colours. It's cheerful and exuberant, restrained and business-like, warm and accessible. And combining different colours gives Cheek a unique, individual style.





Photography Valerie Clarysse

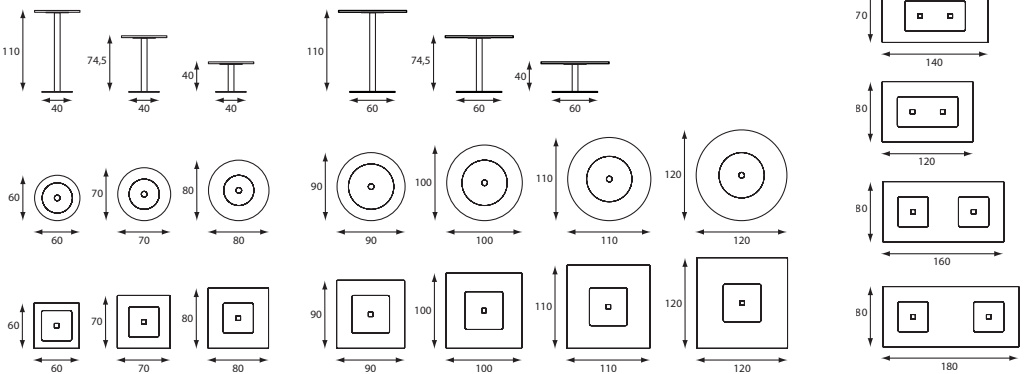

## Square or round.

The secret of Club is its simplicity. In combination with special meeting places, chairs or other elements, Club strikes the right note. Artistic, creative, business-like, welcoming, warm and practical. With Club you can create your own surroundings and atmosphere – together with the MC Sofa system, for example.

Despite, or thanks to, its successful complementary qualities, the Club has remained very down-to-earth. No-nonsense, stable and in three different heights. With a square footplate, square column and square top. Also available as a rectangle and round, round, round.

Club makes other elements more beautiful.





## A slim, practical helper.

A slim, handy side table that's slightly cheeky, flexible and right for any place. And a table in which the shape and characteristics of a leaf can be seen at a glance: slim, light, flexible and yet strong and stable. Easy to stow and bring out when you need it. A beautiful, practical solution when you have your hands full.

The top looks rather as if it's held by a waiter and provides enough space for a cup of coffee, a smartphone or a tablet. The frame is available in various fresh powder coatings, with either a matching or contrasting colour for the top.

At home anywhere, and particularly in combination with the seating elements of 1st Class, Rondo, Dots Up and Dug Out.

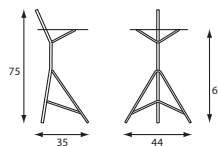



Photography Valerie Clarysse

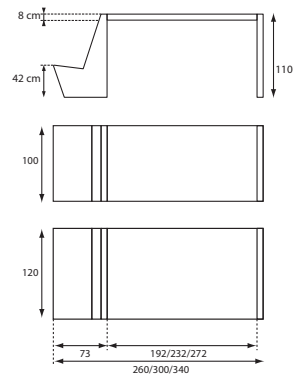
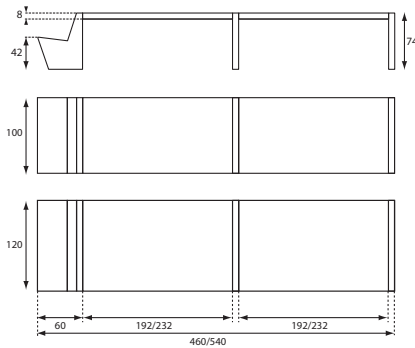
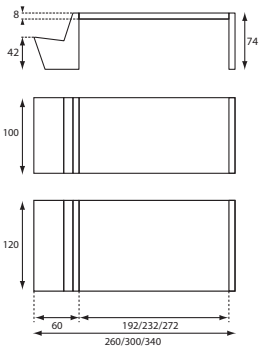



## Find your Level.

Is it a sofa or a table? With this sophisticated style-setter, you no longer have to choose. Its playful design simply invites you to take part. To chat, discuss, present, eat or study. Level makes it special.

There's a Level for yourself, with a sofa for a leg. It makes a great desk. Striking and practical. If there are more people and you want to meet and discuss as a group, the extended Level is just the place for it. Here you can work, think, play, do nothing or give everything. In short, just be yourself at a beautiful table.

Because of the thickness of the sides and top, and its sturdy metal construction, the Level can soak up a lot of punishment. Need more space? Just link them together. And for people who prefer to stand, there's even a high model. With the same solid characteristics and quality.

Level. Let's get around the table.



## The meeting/table tennis table.

Ping is a table that gives you energy. Here you can combine effort and relaxation, work and fun. It's a table that you can use for meeting, eating, reading, playing and sport. Everything. A beautiful slim-line table for exchanging views, or table-tennis shots!

Richard Hutten is internationally famous for his unusual designs. He has this to say about Ping: 'Thanks to the digital revolution, we are constantly "on", so it's important to take the time for relaxation and enjoyment. Ping can be turned into a table tennis table in an instant, for a bit of healthy fun.'

The top is divided into sections with a beautiful walnut inlay, which is handy if you need to seat four and also as lines for the table tennis. There are drawers in the short sides containing two bats and a net.

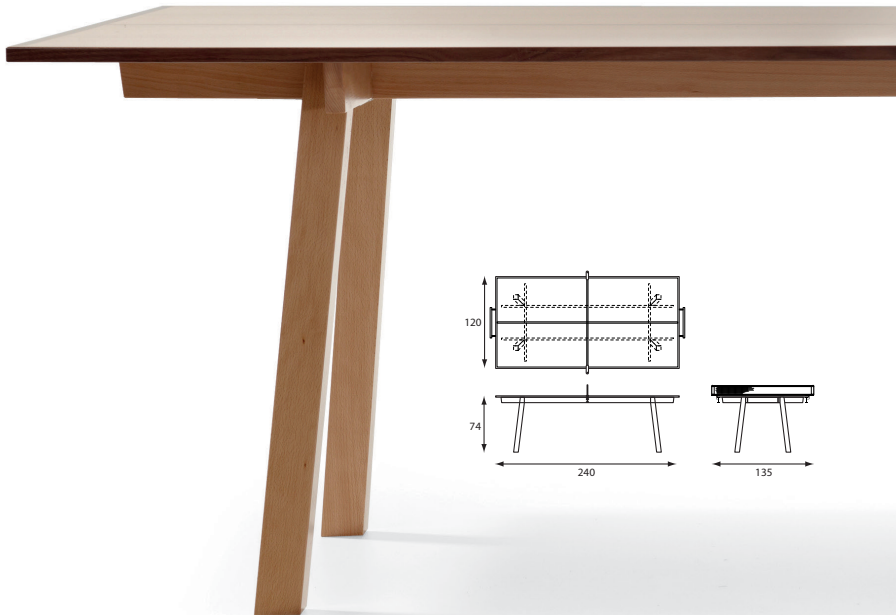



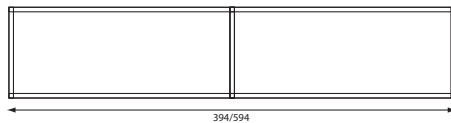
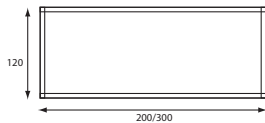
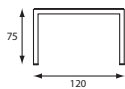
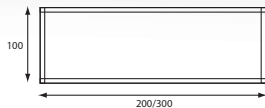
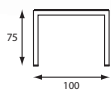
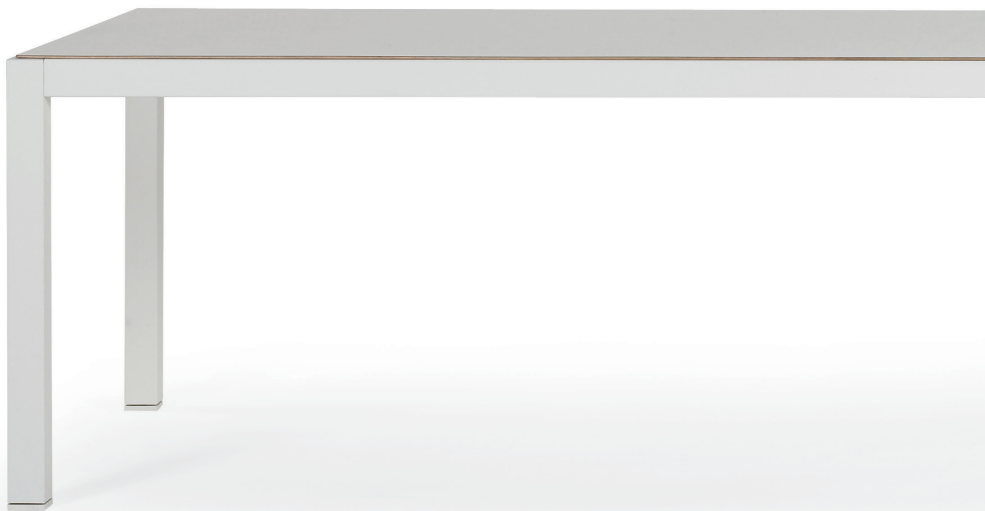

## A table in its most elementary form.

Stylishly restrained, Slick makes a great impression everywhere – in workplaces, meeting rooms but also, of course, at home as a dining table or worktable.

A fine detail is the top that is slightly recessed, giving it an extremely thin appearance. But that's at first sight, because the top is actually sunk into the frame. And because it can be linked together, Slick is also an ideal table for larger groups, whether you're just enjoying each other's company or holding a brainstorming session.

Slick. Back to the basics.



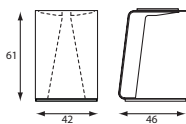

## A side table for brilliant ideas

A quick scribble, a rough sketch, fleshing-out an idea – it can all be done on paper. And the T-pad was made for it. - This is a side table that's always at hand when you need it. The top slopes towards you, inviting you to set down your thoughts with pen and paper. Or to doodle while you listen intently. A strong combination of bent steel, colour powder coated, a ring of felt and a sketch-block.

Not just for its design, but for anywhere a side table and good ideas are needed.



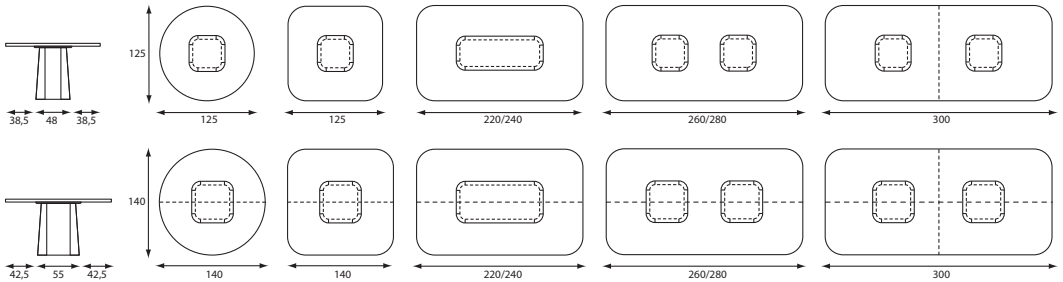



## A table to gather round.

Teska is a table that invites you to gather around it and relax. Sturdy, robust and yet, thanks to its rounded shape, slightly soft. There are no angles but flowing lines and curves. And it has a frame that you simply can't ignore – massive and as strong as a tree-trunk. This is a real table! Just sit down, alone or with the entire team, to share, laugh and, of course, for more serious work.

Teska's veneered column leg makes its appearance authentic and recognisable. You can link tables together and make them as long as you want.

Teska. A welcoming sight in company restaurants, libraries, schools and meeting rooms.





Photography: © Paul Ott, Graz

## Trigon Slim Desk

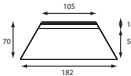
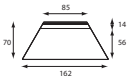

## Trigon Desk

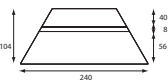
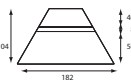

## Trigon Rhomb Desk



## Trigon Simple Desk

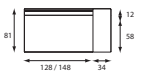
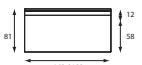

## Trigon Shelf



## Trigon Shelter



## Trigon Acoustic Wall

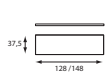

## Trigon Book Storage



## Trigon Storage



## Trigon Shelf



## Flexibility – Modularity – Diversity

TRIGON, a revolutionary table and desk system, is designed to fulfill modern workday life's needs by optimizing the workplace with flexible furniture for work, play and collaboration

In addition to classical rectangular table layouts and row formations, the most innovative aspects of TRIGON are exemplified with individual table settings that enable the user numerous different layouts in an open space. The modular table components can be combined with special features like sound absorbing dividers, shelves and shelters offering a more private workspace.

See our brochure "TRIGON – Break the right angle" for more information.





## Break out of the pattern.

Open and free. These individual elements allow you to break out of your regular patterns.

Hot Desk is perfect for spontaneous meetings and brief discussions. Its long legs give it the right height, and it makes a striking gathering point in any setting.

Hot Desk turns a simple standing area into an adventurous comfort zone. This is where new ideas and cooperative ventures are born. It is effective and flexible, in moments of both peak activity and calmness.

It is a design by the award-winning design collective 13&9.

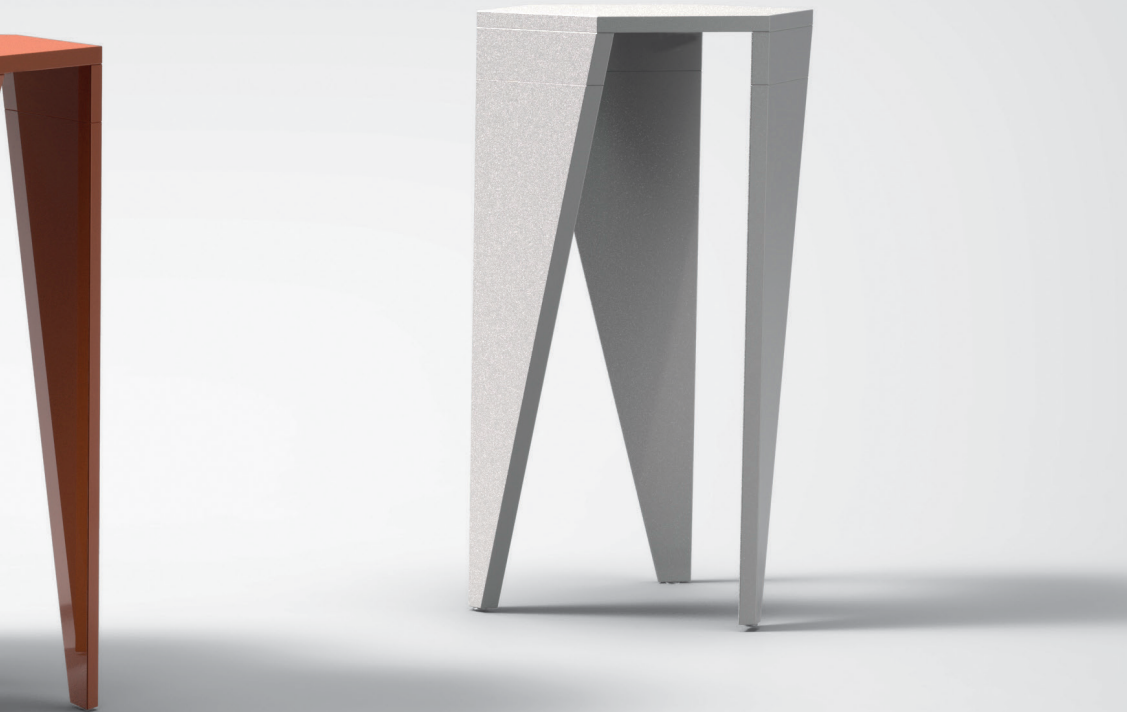
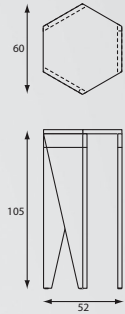



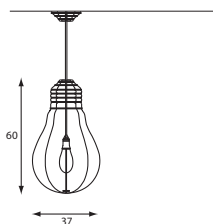

## A trendy take on the classic light bulb.

Until recently, every lamp used the familiar pear-shaped light bulb. Now it won't be long before all light bulbs will be replaced with energy-efficient light sources. Which is good for the environment, of course. But for those of us who don't want to do without the old, trusted light bulb, there's now the Illumimate: a beautiful hanging lamp that's 60cm high, with a diameter of 37 cm.

With the Illumimate, designer Ernst Koning wants to pay homage to the shape and practicality of the light bulb. This new light bulb, made of triplex or acrylate, lends a striking and light-hearted accent to every interior.

The Illumimate. Innovative, timeless and durable. With an energy-saving or LED bulb, of course.



## An industrial lamp. With an ingenious plug.

A lamp that has been much admired. With the Refinery, designer Ernst Koning won the IF Concept Design Award 2012, one of the biggest international design prizes for young talent.

The refinery unites simplicity, surprise and practicality. The design has a timeless, industrial look and is inspired by oil refineries.

This hanging lamp has five tubular arms that move independently. This is not only beautiful but handy if you want to direct extra light – ideal if you're sitting at the table in a large group, working or reading. The lamp constantly looks different. And if you need power, there's an electrical plug in one of the tubes. So no more messy cables on the floor. It's also practical for flexi-working and as a meeting place.

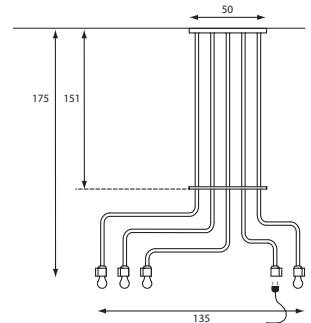
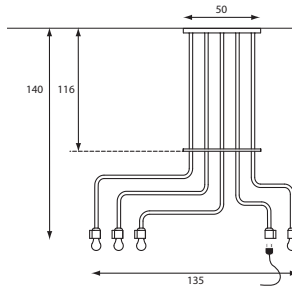
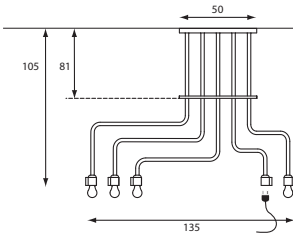







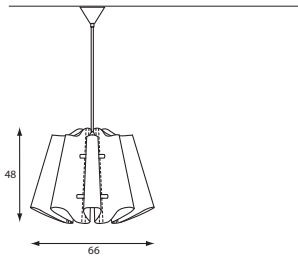

## Light that you can almost feel.

The lampshade is folded to create two rings of light, so it almost seems as if you can actually touch and feel the light. Tangible Light is a lamp as sculpture. Something happens when you switch it on. The light carries the lamp and the room appears to change.

Nature is a major source of inspiration for designer Floris Wubben. And combined with his interest in traditional craftsmanship and technology, this results in exceptional designs. Like the waves of stitched polypropylene elements held together by light and wood.

Tangible Light. Beautiful in the home, office, meeting place and meeting room.



## Beautiful metal

Cabinet 45 proudly displays its craftsmanship and the production process behind it. The beauty of its simplicity lies in its visible folding seams and its stunning construction.

Cabinet 45 fits every interior and gives it a special accent. And that's partly due to its beautiful powder-coat colours. Serious yet slightly tongue-in-cheek.

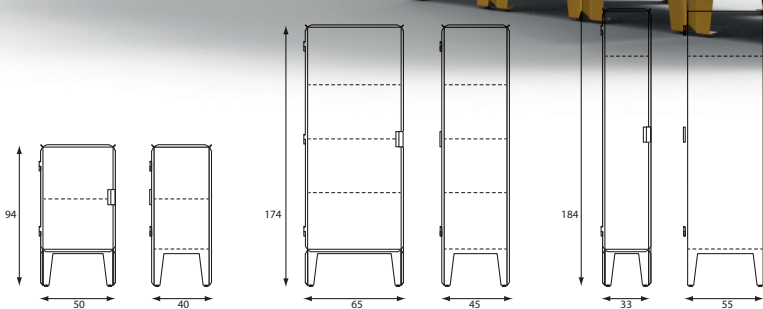

## Startling design. A unique bookshelf.

Ready for something completely different? At home or at a workplace? Something distinctive and unusual? 6 Degrees gives every room a striking, playful accent. Huib von Essen designed it to add something special. It has also been made with respect for people and planet. And you can see that reflected in this beautiful, lighthearted cupboard, made from a single sheet of plywood.

A cupboard with open sides – airy and light. The 6-degree angle of the shelves keeps books together. The cupboard has five compartments and is natural lacquered or stained, allowing you to continue to see the beauty of the material. A single cupboard provides a special accent – with a wall of cupboards, you create your own room. Different. Striking. Unique.

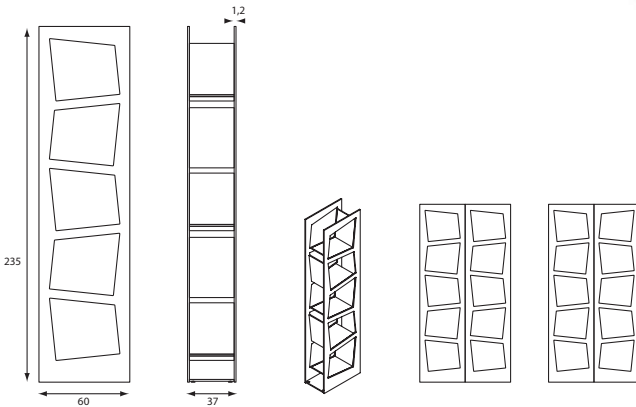



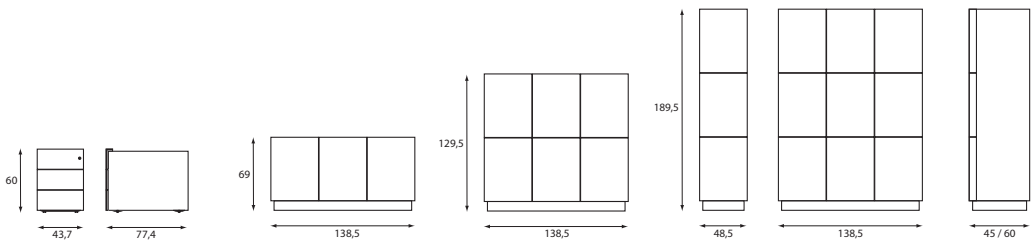



## Symmetry and an interplay of lines. A cupboard with class.

A door that reaches right to the edge. Divided into equal compartments. Symmetry and an interplay of lines. And the system also combines beautifully...and practically. Finely crafted in every detail for a business-chic look, a loft look or a creative accent.

Can be used right up against a wall, but also to divide workplaces or larger areas. If you want to adopt this style completely, the drawer units are a great addition. Handy at every workplace.

System. Create space and atmosphere with these modern, stylish cupboards and drawer units.



## A cupboard with endless possibilities.

Wiet can be used in all sorts of ways – as a separate cupboard or as a row of cupboards next to each. Experience the power of repetition, play with the lines and layout, and enjoy the result. Wiet is a cupboard, divider and showcase in one. Beautiful in the living room, the library or exhibition space, for example.

However you look at it, Wiet is for showpieces and practical items. In rooms large and small. And even in very big rooms, in the form of an impressive room divider, for example.

There are various heights, widths, shelves and drawers available. Enabling you to constantly modify, extend and configure the cupboards differently. Combine Wiet and enjoy new possibilities.



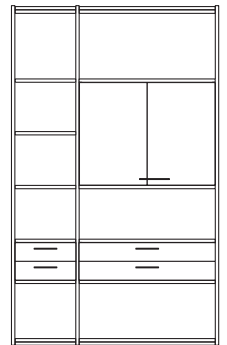
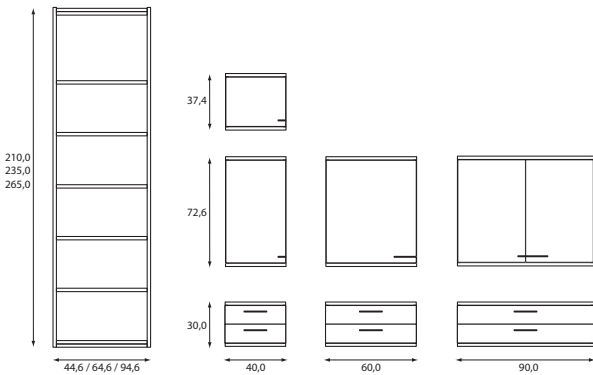



### From furniture to a multi-functional environment.

Technology is an essential part of our everyday lives. It often starts with gadgets for the 'early adopter'. The technology then progresses into practical applications. Two decades ago, mobile telephones and the Internet were very exciting new developments. The generation that is now entering the labour market has grown up with them and can't imagine life without them. These people intuitively turn to the fastest means of communication. The smartphone is the controller of their environments.

When the technology enters the business world, matters suddenly get rather more complex. Different systems are used alongside each other and in combination with each other, updates are constantly being published, and employees need to be informed about the use of new systems.

Tech'n and Lande embrace the added value of technical aids, and look for functional applications in existing and new furniture lines. Technology that satisfies your wishes, or sets a new manner of working in motion, with an eye for accessibility, and above all practical to use and maintain.

Got a question? We would be happy to contribute ideas. We offer advice, development, and support in such matters. Send your question to [info@techn.nl](mailto:info@techn.nl)



#### Hardware

Screens /displays  
Speakers  
Mechanisms  
Lights  
Microphones  
Cameras  
Touch panels

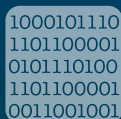

#### Control

Switches  
Internet protocol  
Domotics  
Apps for tablet or smart phones  
Sensors  
WiFi/WiDi



#### Connection

USB (5V / 12V)  
HDMI / VGA  
CAD/Ethernet  
Mains voltage  
Chargers  
Cable management



#### Service

Advice  
Help desk  
Programming  
Software  
Maintenance





## Lande

P.O.Box 115  
5480 AC Schijndel  
T +31 (0)73 658 0050

info@lande.nl  
www.lande.nl

www.twitter.com/LandeProjects  
www.facebook.com/LandeProjects

